



**for fresher air**

# **Air Handling Units**



**direct drive - belt drive - custom built**

# direct drive - belt drive - custom built *Air Handling Units*



## Introduction

Vectaire's comprehensive and extensive range of air handling units from "Compact" plant room models to custom built belt driven models able to deliver up to 20m<sup>3</sup>/sec ensures that any installation requirement can be met.

## Design brief

To provide a comfortable, healthy environment, often without loss of heat and a multiplicity of parameters -

**The occupants** want a non-intrusive system.

**The designers** want to ensure that air exchange is optimised whilst bringing fresh air into the building.

**The builders** need a reliable product that can be easily installed and set up.

**The answer** lies in well thought out, efficient ventilation.

**The correct ventilation** method is an air handling system which encompasses all of the above.

## What product to choose?

Stricter rules governing air tightness of buildings means more emphasis on controlled fresh air supply. Air handling units, which are easy to install and which have a wide variety of options, will effectively ventilate the required area providing a healthy atmosphere for people to work and play. Vectaire's range of units, together with comprehensive, computerised design facilities, gives the specifier the ability to choose a fan capacity which ensures a proper level of ventilation, together with **heating, heat recovery, acoustic level and control options**.

## Flexibility

Vectaire's range of Air Handling Units are available in an extensive range with a variety of options which contribute to their versatility of use and ensure that exactly the correct unit can be specified. There are direct drive versions either electrically or hot water heated together with belt driven units for bigger airflow requirements. Combine this with the facility for custom built systems, and the flexibility of design and use is infinite.

## Technical Support

With its firm commitment to quality and customer care, Vectaire's technical support staff can help with the design of any ventilation system to ensure that it is the most cost effective and efficient available.

## Installation

Vectaire can advise on installing and commissioning your air handling unit system and can give full technical back-up.

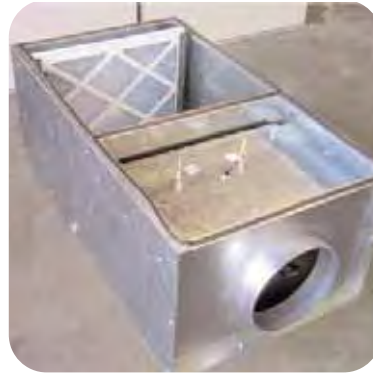

# direct drive - belt drive - custom built *Air Handling Units*

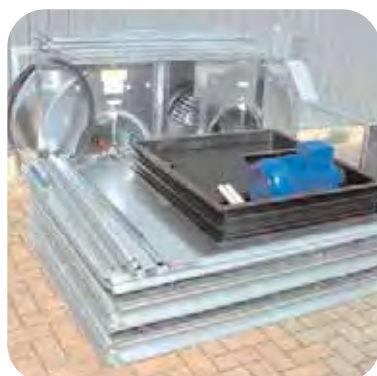
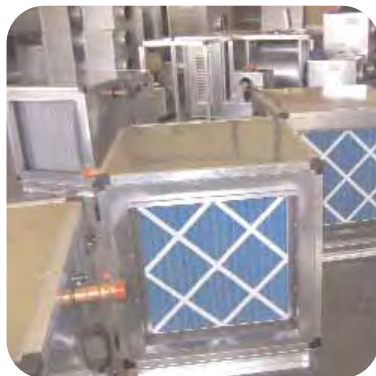

## Quality Control

Vectaire Air Handling Units are manufactured to the highest quality and inspected at every stage of the manufacturing process. All products are built to BSEN ISO 9001. We operate a continuous evaluation of products and services to ensure customer requirements are met in full.

## Materials

Vectaire Air Handling Units are generally finished in galvanised, double skinned steel with 25mm thick mineral wool slab insulation and have a triple layer of steel at the corners with pre-drilled 8mm dia holes providing an ideal location for fixing points.

All panel filters are manufactured from bonded and coated continuous spun glass fibre filaments with arrestance of 84% to G3 grade.

## Heating Control Panels

Designed for quick and easy installation with external wiring kept to a minimum. A mains supply is taken to the panel door interlocked isolator and outputs then taken to the fan, heater and safety circuits. Sensors are supplied pre-wired to the panel. Switches on the front of the panel allow control of the fan and heater. All outputs to the fan are protected. All control panels are BMS compatible.

## Options

A full range of accessories and controls are also available - these include

- **intake damper/mixing box**
- **electric or hot water frost heaters**
- **bag filters**
- **cooling coils**
- **heat recovery systems**
  - cross flow heat exchangers
  - thermal wheel
  - run around coils
- **alternative heating source**
  - gas fired
- **casings**
  - 50mm panels can be supplied with high density rockwool and barrier matt.
  - can be constructed in a vertical or horizontal layout
  - can be supplied as "flatpack" form to facilitate on site reassembly

## Manufactured in UK to ISO9001

# Direct Drive - Air Handling Units

## Selection Chart

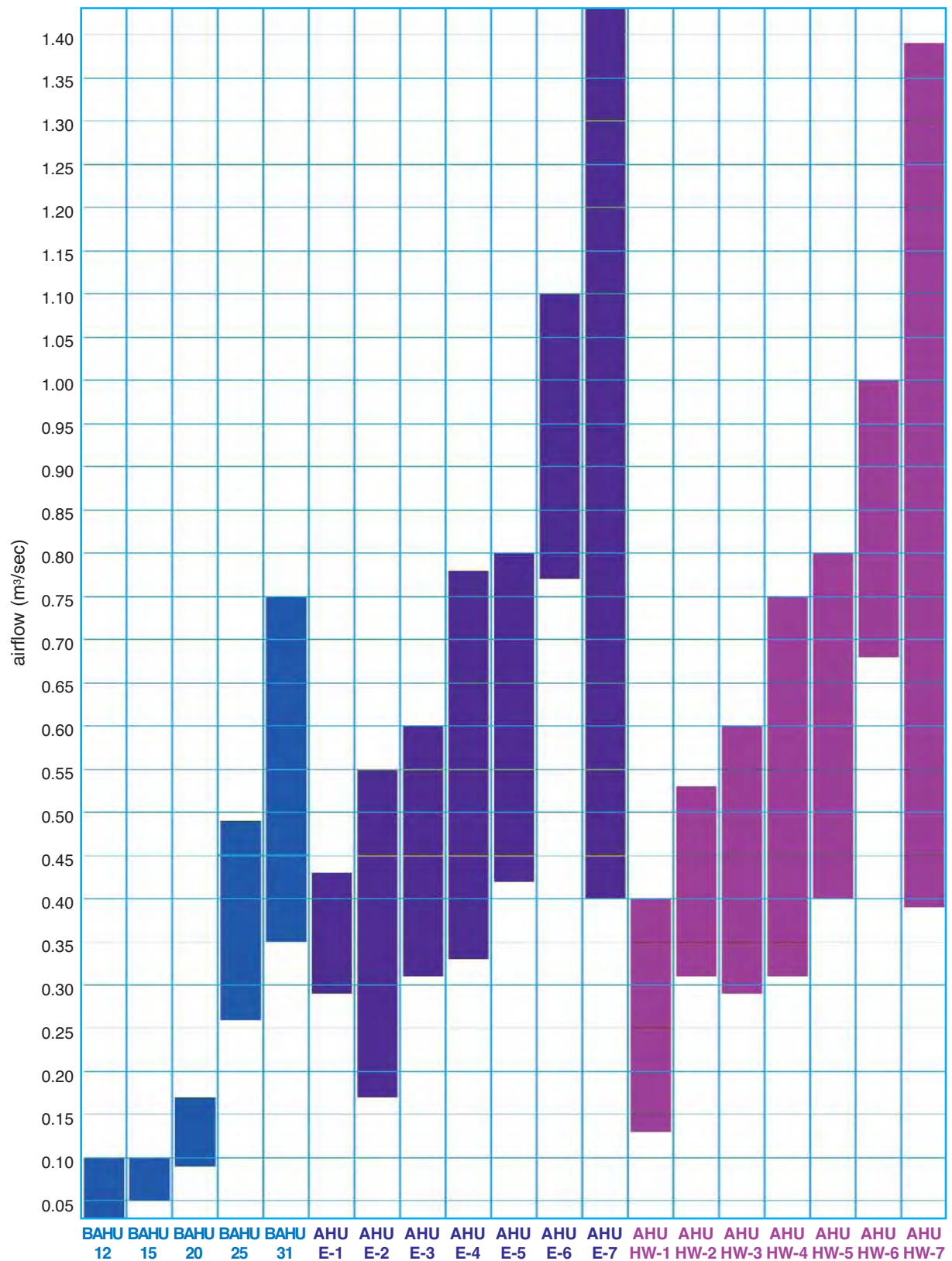

See page 5 for BAHU details, page 9 for AHU-E details, and page 15 for AHU-HW details

## "BAHU" - compact

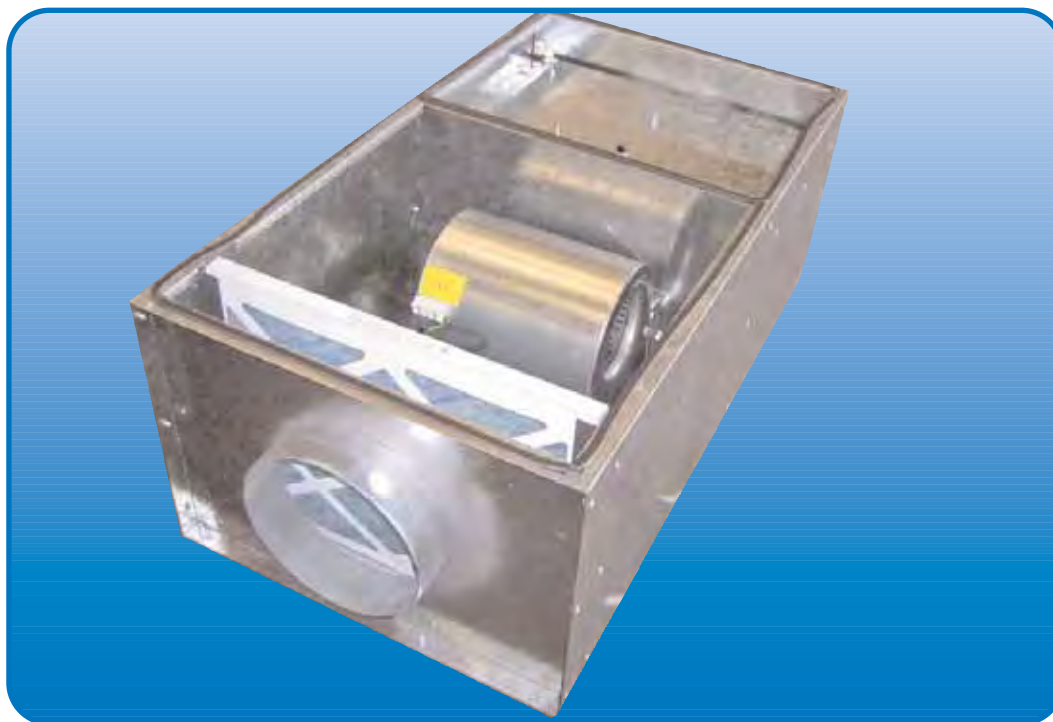

### Features - PLANT Models

- electrically heated
- 5 models for duct installation - BAHU
- airflow from 0.001 to 0.75 m<sup>3</sup>/sec
- pressure to 350 Pa
- speed controllable
- single skinned spangled galvanised steel cases with 25mm thick acoustic lining
- panel filter fitted into slide-in channels
- can be mounted horizontally or vertically with access either on bottom or top
- complete with integral mounting points for either floor or ceiling mounting
- quick and easy to install
- LPHW model available - please contact technical department for details

### Additional Features - WEATHERPROOF Models

- external models available with top access via a single removable weather lid - BAHU-R
- air intake side protected by weather proof cowl and bird guard

- external models in galvanised steel, single skin with plastisol exterior in light grey to BS10A05
- LPHW model available - please contact technical department for details

### Specification

- the fans are double inlet, double width, forward curved centrifugal fans.
- fan blades statically and dynamically balanced in accordance with VDI2060 and ISO1940/1
- direct drive induction motors with IP10 protection.
- insulation Class 'O' barafom
- A manually reset table thermal cut-out is an integral part of heater control circuits. It is recommended that fans should be operated via a run-on timer incorporated within the controller.
- maximum air temperature 40°C
- panel filters manufactured from bonded and coated spun glass fibre to EU3 grade, fitted as standard in easily removable housings.
- **manufactured in UK to ISO9001**



### Performance

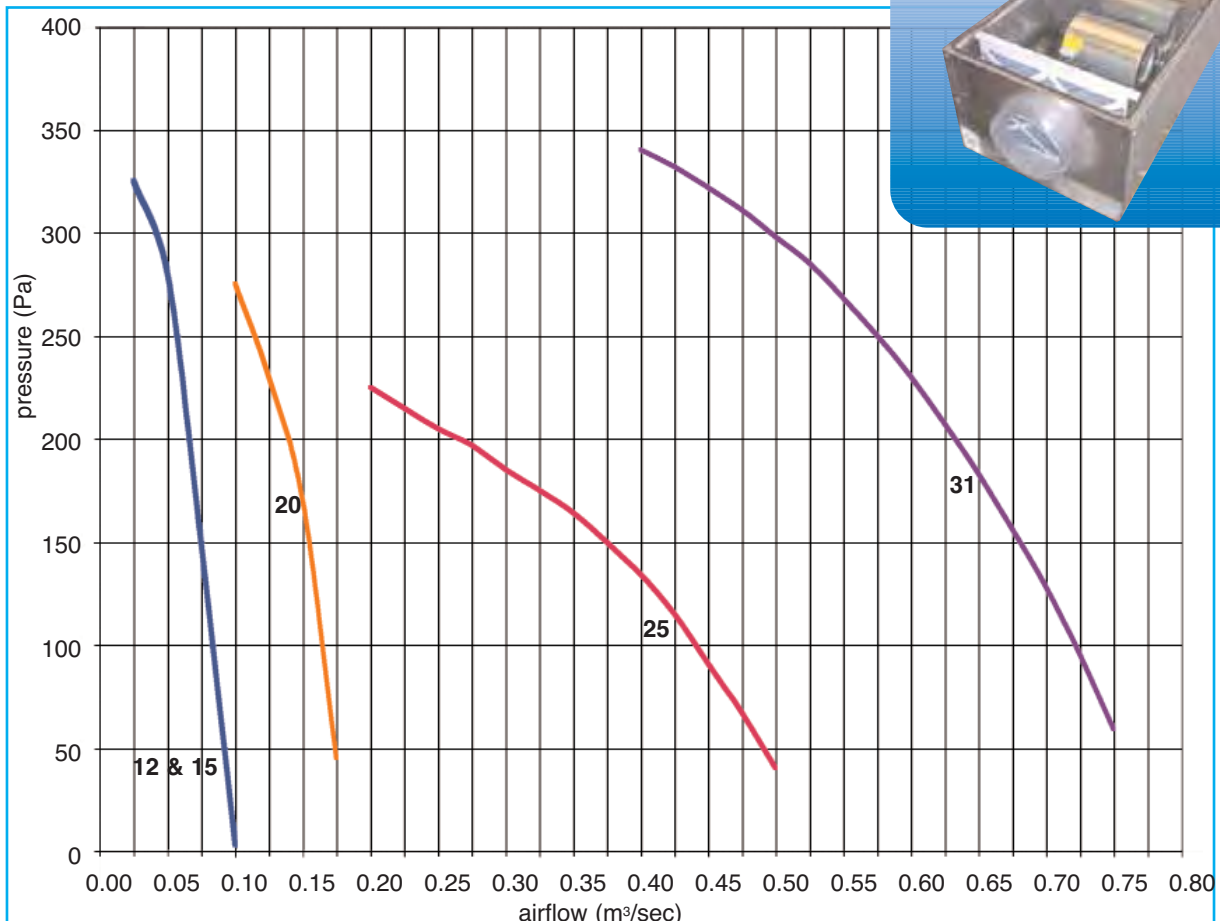
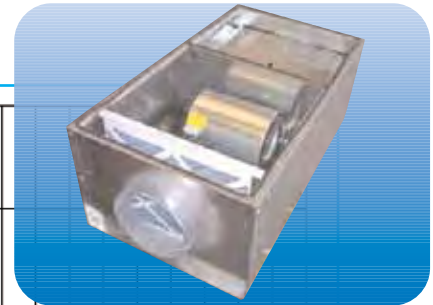

Performance curves are based on "clean filter" conditions. An additional 80Pa should be added to the external pressure of the product for unit selection at a "mean dirty" condition

Range - D and R	
BAHU12	BAHU25
BAHU15	BAHU31
BAHU20	

Model	m³/sec at Pa								Fan				Sound Pressure Level dBA@3m	Speed Controller
	0	50	100	150	200	250	300	350	Supply	Power W	FLC A	SC A		
BAHU12	0.100	0.092	0.085	0.075	0.068	0.060	0.040		230v 1ph	135	0.63	1.60	58.0	VC1
SFP	1.35	1.35	1.40	1.69	1.73	2.01	3.50							
BAHU15	0.100	0.092	0.085	0.075	0.068	0.060			230v 1ph	135	0.63	1.60	58.0	VC1
SFP	1.35	1.35	1.40	1.69	1.73	2.01								
BAHU20		0.174	0.165	0.155	0.140	0.115	0.100		230v 1ph	190	0.85	2.20	50.0	VC1
SFP		1.07	1.10	1.15	1.27	1.53	2.29							
BAHU25		0.490	0.440	0.375	0.270				230v 1ph	373	3.60	11.20	61.0	VC4M
SFP		0.94	1.04	1.54	2.02									
BAHU31		0.755	0.720	0.680	0.635	0.575	0.495	0.360	230v 1ph	373	3.85	12.00	58.5	VC4M
SFP		0.80	0.80	0.80	0.80	0.80	0.84	1.00						

SFP = Specific Fan Power

## BAHU - *Dimensions*

Model	A mm	B mm	C mm	D mm	Kg
BAHU12	400	225	750	125	29
BAHU15	400	225	750	150	29
BAHU20	475	335	850	200	37
BAHU25	500	400	920	250	45
BAHU31	550	475	970	315	49
BAHU12-R	400	350	750	125	24
BAHU15-R	400	350	750	150	24
BAHU20-R	425	375	850	200	35
BAHU25-R	650	450	900	250	43
BAHU31-R	650	475	900	315	47

### BAHU - Plant Models

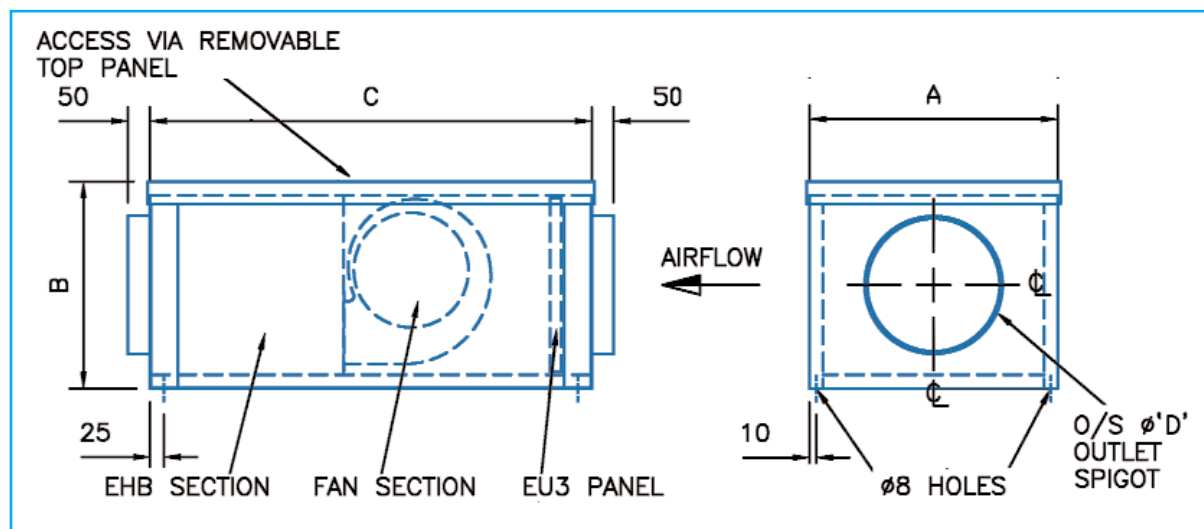

### BAHU-R - Weatherproof Models

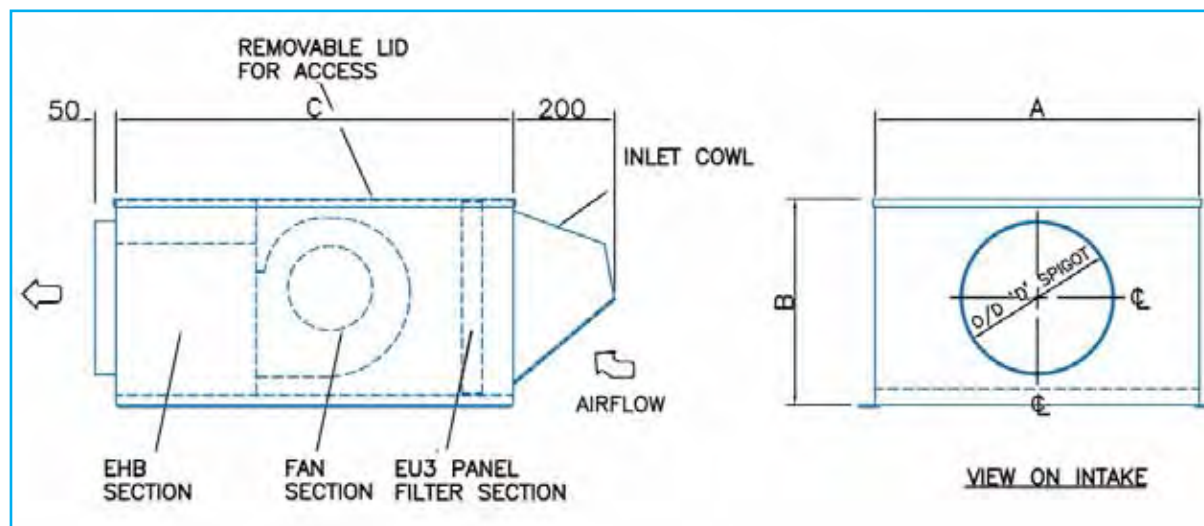

## BAHU - *Silencer & Heater*

### Silencers

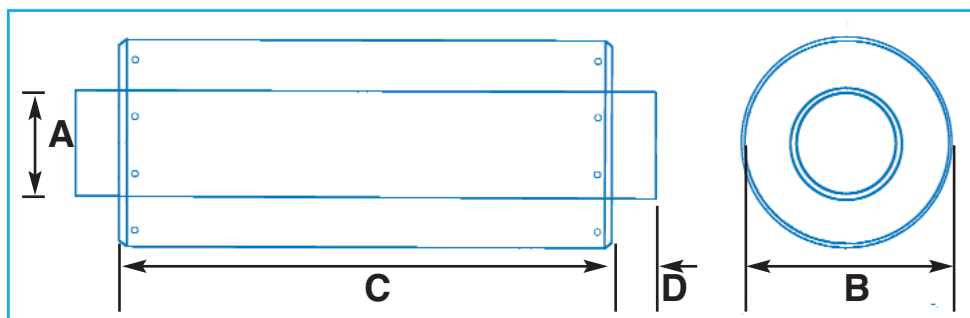

Model	A mm - O/Dia	B mm - O/Dia	C mm	D mm	Kg
SIL125	123	230	600	40	5.4
SIL150	148	255	600	40	6.1
SIL200	198	305	600	40	7.6
SIL250	248	355	600	40	9.1
SIL315	313	420	600	40	12.3

Model	Attenuation: Insertion loss - db - mid frequency Hz							
	63	125	250	500	1000	2000	4000	8000
SIL125	4	8	13	30	35	35	31	15
SIL150	4	7	12	23	30	36	31	15
SIL200	4	6	10	20	27	32	20	11
SIL250	3	6	10	19	25	29	18	10
SIL315	3	5	8	16	21	22	16	14

### Electric Heater Batteries

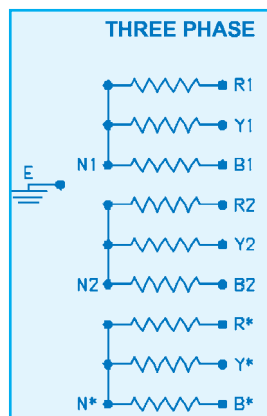
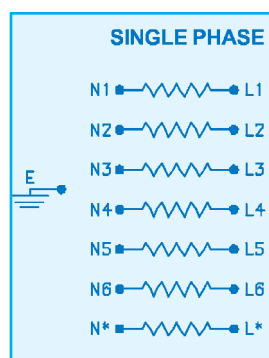

Model	kW Rating	Single Phase Steps					3 Phase Steps				
		1	2	3	4	6	1	2	3	4	
BAHU12 BAHU15	1.5	✓									
	2.0	✓	✓								
	2.5	✓									
	3.0	✓	✓								
BAHU20	2.0	✓	✓								
	2.5	✓									
	3.0	✓	✓								
	4.5	✓		✓							
BAHU25	4.5	✓		✓							
	6.0	✓	✓	✓			✓				
	7.5	✓		✓			✓				
	9.0	✓	✓	✓			✓	✓			
BAHU31	9.0	✓	✓	✓			✓	✓			
	12.0		✓	✓	✓	✓	✓	✓			
	15.0		✓	✓		✓	✓	✓			
	18.0		✓	✓		✓	✓	✓			

# Direct Drive - Air Handling Units

## *Electric Heater*



## "AHU-E" - electric heater



### Features - PLANT Models

- 14 models (7 sizes) for duct or roof installation
- airflow to 1.42 m<sup>3</sup>/sec
- pressure to 350 Pa
- speed controllable
- inlets and outlets fitted with "Mez" type duct connecting flanges
- rigid casing construction with triple layer of steel at corners - 8mm dia integral fixing point at each corner for either floor or ceiling mounting
- optional casing materials include stainless steel or aluminium - can be powder coated to any BS or RAL colour
- bag and panel filter fitted into slide-in channels
- top access on duct mounted models (bottom access can be provided if required)

### Additional Features - WEATHERPROOF Models

- top access on roof mounted models (via a single, removable weather lid)
- air inlets on external units protected by weather proof cowl and bird guard
- roof mounted units constructed in galvanised steel, single skin with plastisol exterior in light grey to BS10A05

### Specification

- internally mounted units are finished in galvanised, double skinned steel with 25mm thick mineral wool slab insulation of 65 kg/m<sup>3</sup> density (providing high degree of acoustic insulation) (50mm panels with

high density rockwool and barrier matt also available for lower sound levels)

- fans are double inlet, double width, forward curved centrifugal type, mounted on integral anti-vibration mounts
- motors - with thermal overload protection
- electric heater batteries for single and 3 phase operation are manufactured from sheathed rod elements with an integral, manually resettable thermal cut-out for wiring into control unit
- maximum air temperature 40°C
- panel filters manufactured from bonded and coated spun glass fibre to G3 grade, fitted as standard in easily removable housings. Higher degree of filtration can be provided on request
- **manufactured in UK to ISO9001**



Heating Coil



### Fan, Filter and Electric Heater Battery

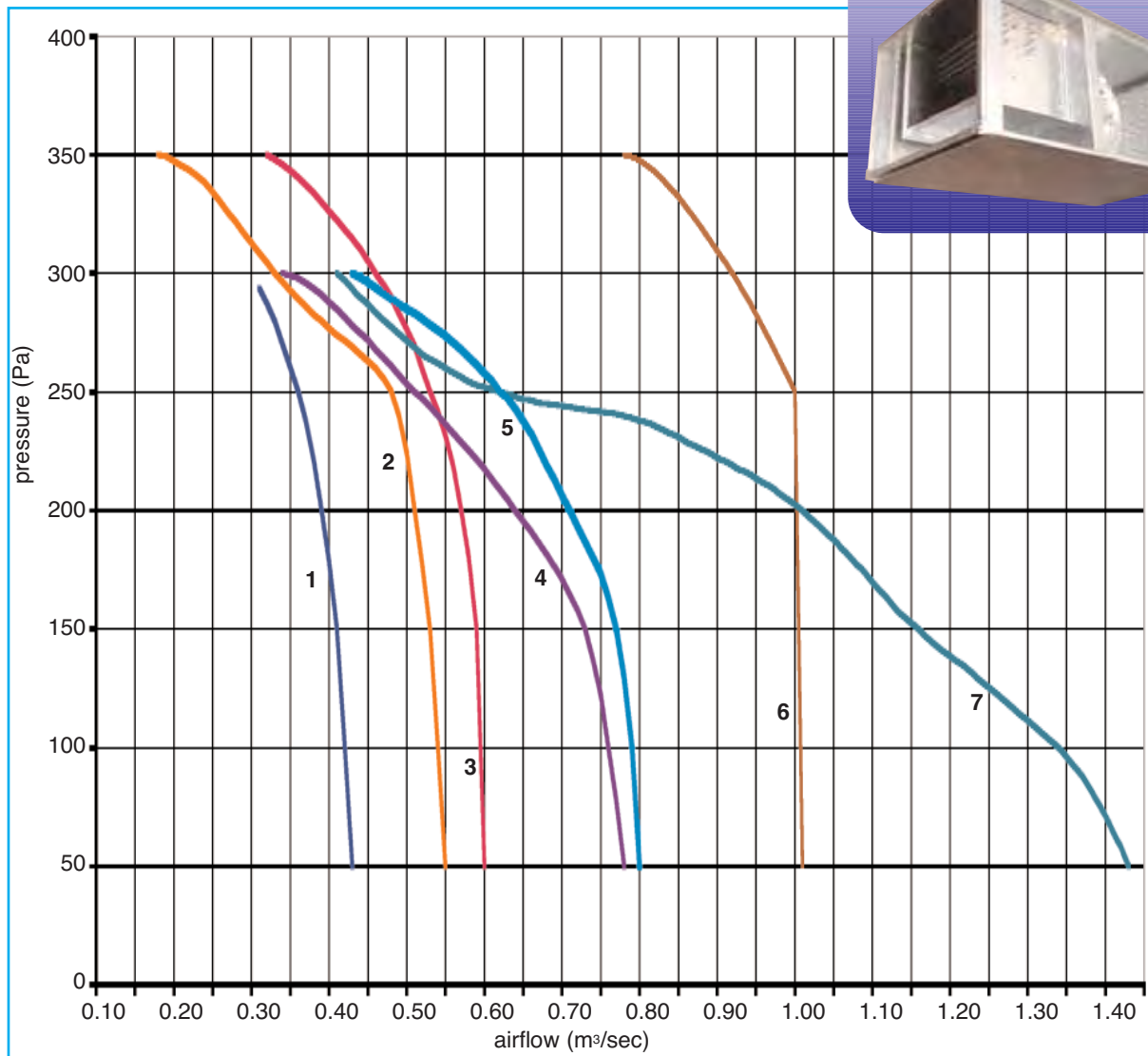

Performance curves are based on "clean filter" conditions. An additional 80Pa should be added to the external pressure of the product for unit selection at a "mean dirty" condition

	Range	
	Plant	Roof
1	AHU-E-1-D	AHU-E-1-R
2	AHU-E-2-D	AHU-E-2-R
3	AHU-E-3-D	AHU-E-3-R
4	AHU-E-4-D	AHU-E-4-R
5	AHU-E-5-D	AHU-E-5-R
6	AHU-E-6-D	AHU-E-6-R
7	AHU-E-7-D	AHU-E-7-R



## Fan, Filter and Electric Heater Battery

Model	m³/sec at Pa							Fan				Speed Controller
	50	100	150	200	250	300	350	Supply	PowerW	FLC A	SC A	
AHU-E-1	0.43	0.42	0.41	0.39	0.36	0.30	-	230v 1ph	373	2.00	5.00	VC4M
SFP	0.95	0.97	1.02	1.11	1.33	2.35	-					
AHU-E-2	0.55	0.54	0.53	0.51	0.48	0.33	0.18	230v 1ph	373	2.85	7.13	VC4M
SFP	0.74	0.75	0.78	0.83	0.99	1.21	2.22					
AHU-E-3	0.60	0.60	0.59	0.57	0.53	0.46	0.32	230v 1ph	373	3.85	9.63	VC4M
SFP	0.67	0.67	0.68	0.70	0.75	0.87	1.25					
AHU-E-4	0.78	0.76	0.73	0.64	0.50	0.34	-	230v 1ph	550	3.80	9.50	VC4M
SFP	0.65	0.66	0.69	0.79	1.01	1.48	-					
AHU-E-5	0.80	0.80	0.77	0.71	0.62	0.43	-	230v 1ph	550	4.80	12.00	VC7M
SFP	0.63	0.63	0.65	0.71	0.81	1.17	-					
AHU-E-6	1.00	1.00	1.00	1.00	1.00	0.92	0.78	230v 1ph	550	6.80	17.00	VC7M
SFP	0.60	0.60	0.60	0.60	0.60	0.65	0.77					
AHU-E-7	1.43	1.34	1.16	1.00	0.62	0.41	-	230v 1ph	736	7.40	18.50	VC8M
SFP	0.51	0.55	0.63	0.74	1.19	1.79	-					

Performance curves are based on "clean filter" conditions. An additional 80Pa should be added to the external pressure of the product for unit selection at a "mean dirty" condition.

### See page 14 for Heater Battery Details

A 3-phase electricity supply **must** be used for the heater battery if it is rated over 18kw (regardless of the fact that the fan is single-phase)

SFP = Specific Fan Power

## Fan Outlet Sound Levels

Model	Sound Pressure Level db A at 3m	Sound Power Levels db							
		Mid Octave Bands (Hz)							
		63	125	250	500	1000	2000	4000	8000
AHU-E-1	40	61	70	70	59	62	54	51	47
AHU-E-2	43	65	73	68	67	67	62	59	52
AHU-E-3	47	76	79	73	73	73	67	65	67
AHU-E-4	45	71	73	66	71	71	69	66	62
AHU-E-5	50	77	79	73	74	77	77	74	69
AHU-E-6	48	75	77	71	73	75	74	71	67
AHU-E-7	48	78	80	72	74	74	73	72	66



### Fan, Filter and Electric Heater Battery - Plant Models

Model-Duct	A mm	B mm	C mm	D mm	E mm	Kg
AHU-E-1-D	1150	600	450	650	500	65
AHU-E-2-D	1150	600	450	650	500	65
AHU-E-3-D	1150	600	450	650	500	65
AHU-E-4-D	1150	750	450	800	500	77
AHU-E-5-D	1150	750	450	800	500	77
AHU-E-6-D	1250	825	500	875	550	92
AHU-E-7-D	1550	900	600	950	650	117

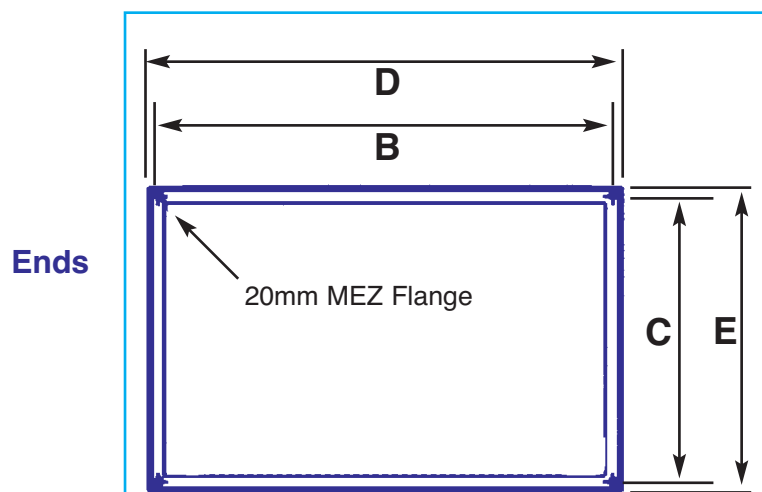
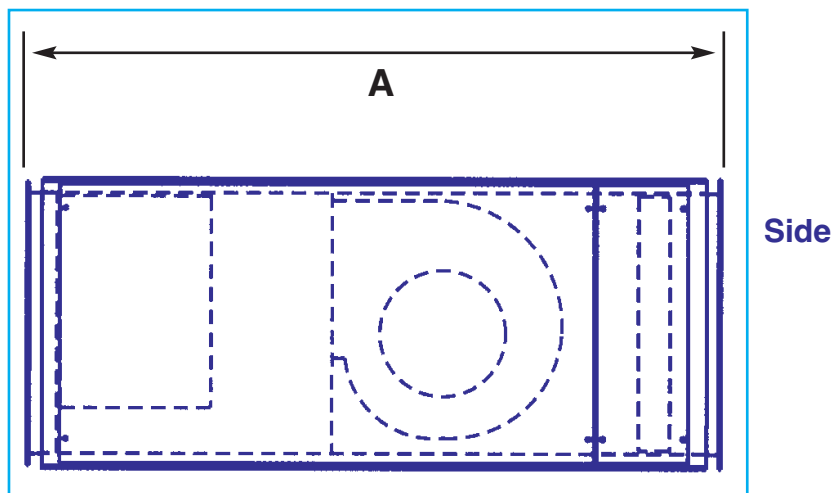



### Fan, Filter and Electric Heater Battery - Weatherproof Models

Model-Roof	A mm	B mm	C mm	D mm	E mm	Kg
AHU-E-1-R	1350	600	450	650	580	57
AHU-E-2-R	1350	600	450	650	580	57
AHU-E-3-R	1350	600	450	650	580	57
AHU-E-4-R	1350	750	450	800	580	66
AHU-E-5-R	1350	750	450	800	580	66
AHU-E-6-R	1450	825	500	875	580	78
AHU-E-7-R	1650	900	600	950	680	97

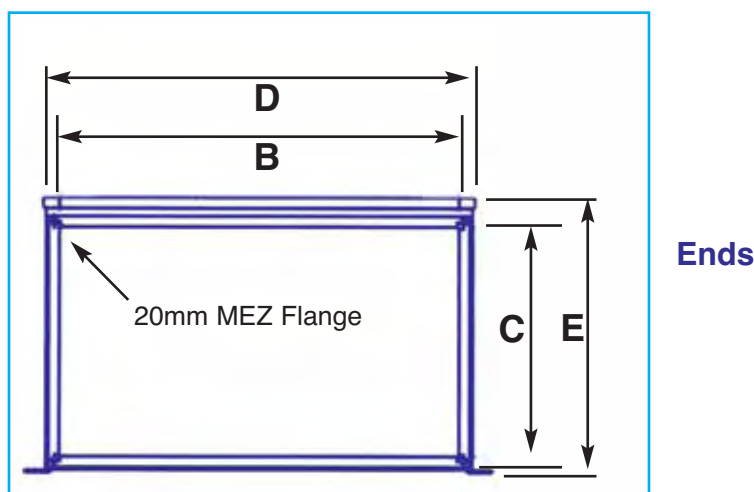
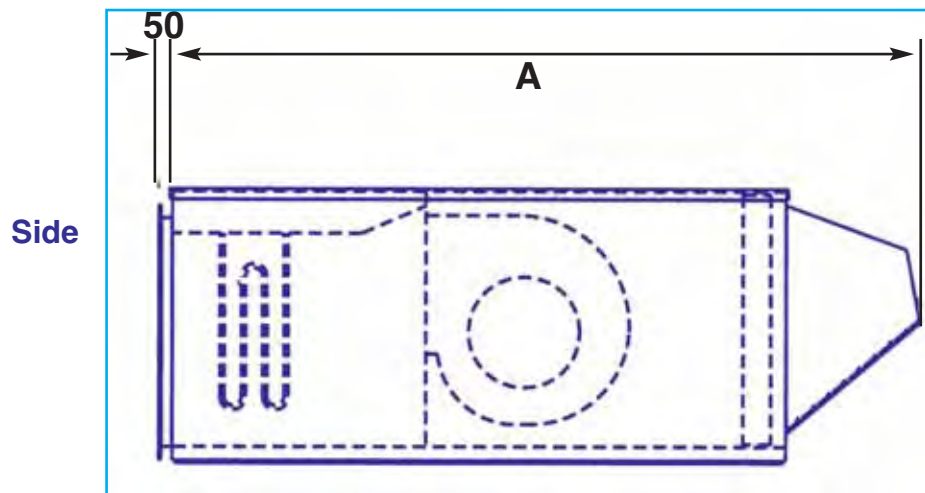

### Electric Heater Battery

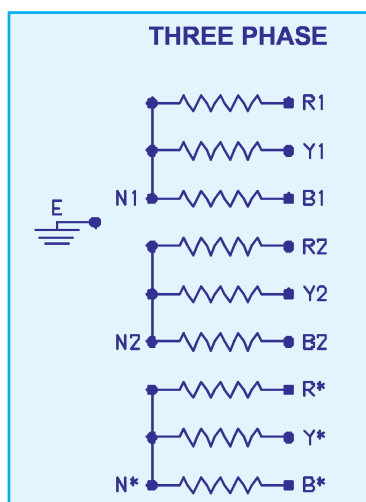
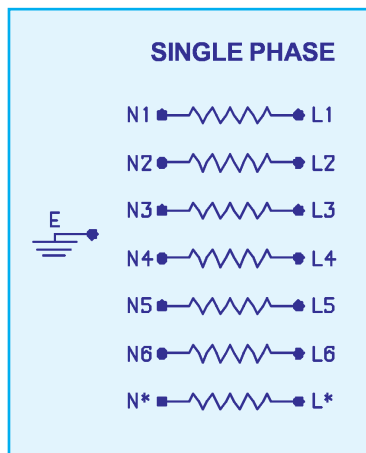

Model	kW Rating	Single Phase Steps					3 Phase Steps				
		1	2	3	4	6	1	2	3	4	
AHU-E-1	3.0	✓	✓								
	4.5	✓		✓							
	6.0	✓	✓	✓			✓				
	7.5	✓		✓			✓				
	9.0	✓	✓	✓			✓	✓			
AHU-E-2	12.0		✓	✓	✓	✓	✓	✓			
	4.5	✓		✓							
	6.0	✓	✓	✓			✓				
	7.5	✓		✓			✓				
	9.0	✓	✓	✓			✓	✓			
	12.0		✓	✓	✓	✓	✓	✓			
AHU-E-3	15.0		✓	✓		✓	✓	✓			
	6.0	✓	✓	✓			✓				
	7.5	✓		✓			✓				
	9.0	✓	✓	✓			✓	✓			
	12.0		✓	✓	✓	✓	✓	✓			
AHU-E-4	15.0		✓	✓		✓	✓	✓			
	18.0		✓	✓		✓	✓	✓			
	9.0	✓	✓	✓			✓	✓			
	12.0		✓	✓	✓	✓	✓	✓			
	24.0							✓		✓	
AHU-E-5	21.0							✓			
	18.0		✓	✓		✓	✓	✓			
	21.0							✓			
	24.0							✓		✓	
	27.0							✓	✓		
	30.0							✓		✓	
AHU-E-6	18.0		✓	✓		✓	✓	✓			
	21.0							✓			
	24.0							✓	✓		
	27.0							✓	✓		
	30.0							✓		✓	
	36.0							✓	✓	✓	
AHU-E-7	21.0							✓			
	24.0							✓		✓	
	27.0							✓	✓		
	30.0							✓		✓	
	36.0							✓	✓	✓	
	45.0							✓	✓		

Heater ratings can be calculated using the following formula:  $KW = m^3/sec \times 1.21 \times Temp\ rise\ ^\circ C$

Dependent on external system resistance and airflow achieved, the temperature rise should not exceed 35°C

## "AHU-HW" - LPHW heater



### Features - PLANT Models

- 14 models (7 sizes) for duct or roof installation
- airflow to 1.40 m<sup>3</sup>/sec
- pressure to 350 Pa
- speed controllable
- inlets and outlets fitted with "Mez" type duct connecting flanges
- rigid casing construction with triple layer of steel at corners - 8mm dia integral fixing point at each corner for either floor or ceiling mounting
- optional casing materials include stainless steel or aluminium - can be powder coated to any BS or RAL colour
- bag and panel filter fitted into slide-in channels
- top access on duct mounted models (bottom access can be provided if required)

### Additional Features - WEATHERPROOF Models

- top access on roof mounted models (via a single, removable weather lid)
- air inlets on external units protected by weather proof cowl and bird guard
- roof mounted units constructed in galvanised steel, single skin with plastisol exterior in light grey to BS10A05

### Specification

- internally mounted units are finished in galvanised, double skinned steel with 25mm thick mineral wool slab insulation of 65 kg/m<sup>3</sup> density (providing high

degree of acoustic insulation) (50mm panels with high density rockwool and barrier matt also available for lower sound levels)

- fans are double inlet, double width, forward curved centrifugal type, mounted on integral anti-vibration mounts
- motors - with thermal overload protection
- LPHW batteries are constructed from copper tubes mechanically bonded onto aluminium fins supplied with standard BSP male connectors
- maximum air temperature 40°C
- panel filters manufactured from bonded and coated spun glass fibre to G3 grade, fitted as standard in easily removable housings. Higher degree of filtration can be provided on request
- **manufactured in UK to ISO9001**



LPHW Coil



### Fan, Filter and LPHW Heater Battery

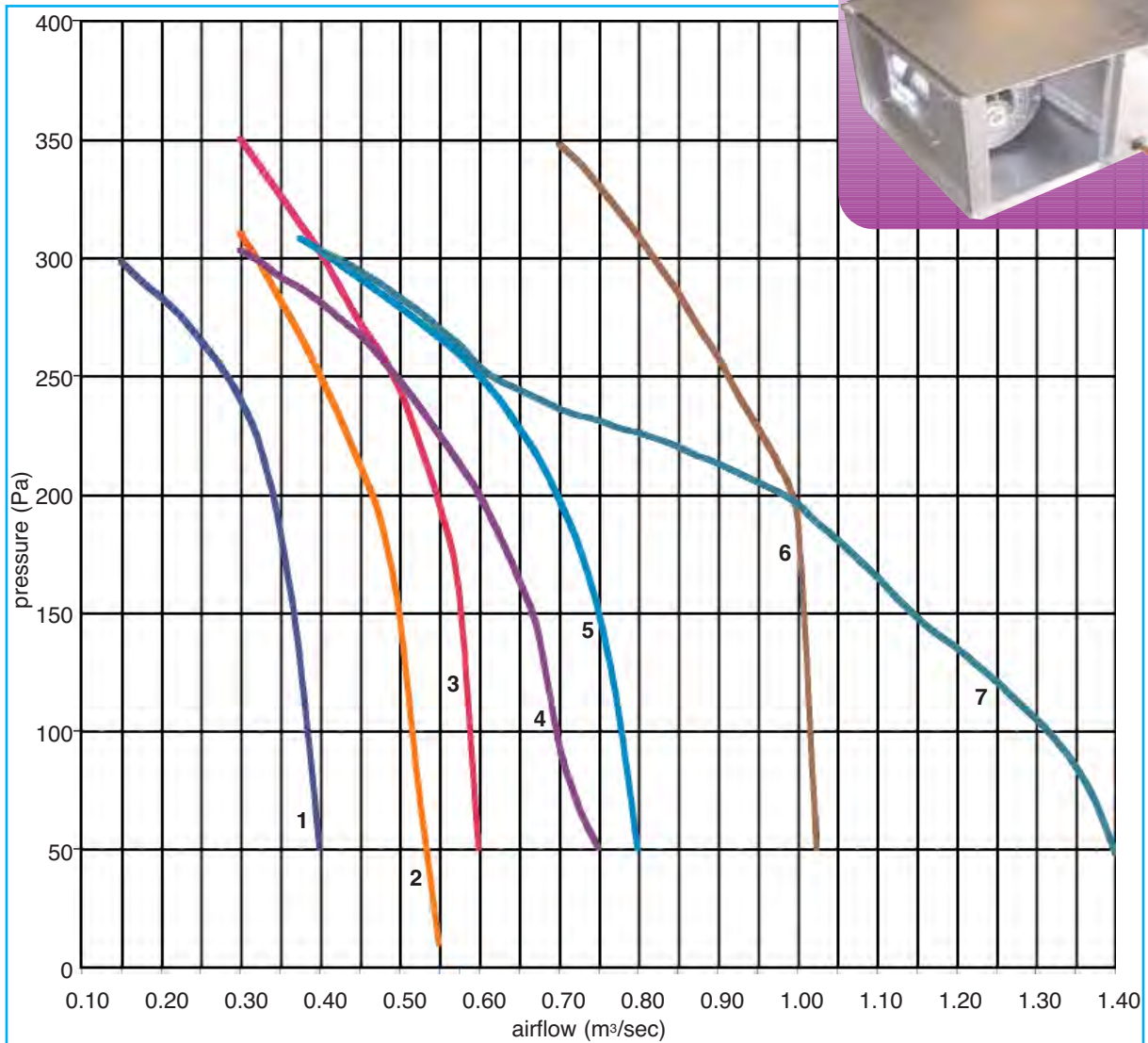

Performance curves are based on "clean filter" conditions. An additional 80Pa should be added to the external pressure of the product for unit selection at a "mean dirty" condition

	Range	
	Plant	Roof
1	AHU-HW-1-D	AHU-HW-1-R
2	AHU-HW-2-D	AHU-HW-2-R
3	AHU-HW-3-D	AHU-HW-3-R
4	AHU-HW-4-D	AHU-HW-4-R
5	AHU-HW-5-D	AHU-HW-5-R
6	AHU-HW-6-D	AHU-HW-6-R
7	AHU-HW-7-D	AHU-HW-7-R



### Fan, Filter and LPHW Heater Battery

Model	m³/sec at Pa							Max Coil kw	Fan				Speed Controller
	50	100	150	200	250	300	350		Supply	Power W	FLC A	SC A	
AHU-HW-1	0.40	0.38	0.37	0.34	0.28	0.14	-	21	230v 1ph	373	2.00	5.00	VC4M
SFP	1.00	1.05	1.08	1.17	1.42	2.85	-						
AHU-HW-2	0.53	0.52	0.50	0.46	0.40	0.32	-	21	230v 1ph	373	2.85	7.13	VC4M
SFP	0.75	0.77	0.80	0.87	1.00	1.25	-						
AHU-HW-3	0.60	0.59	0.58	0.54	0.49	0.41	0.30	21	230v 1ph	373	3.85	9.63	VC4M
SFP	0.67	0.68	0.69	0.74	0.81	0.97	1.33						
AHU-HW-4	0.75	0.69	0.67	0.60	0.48	0.32	-	29	230v 1ph	550	3.80	9.50	VC4M
SFP	0.67	0.67	0.69	0.79	1.01	1.49	-						
AHU-HW-5	0.80	0.78	0.75	0.69	0.60	0.41	-	29	230v 1ph	550	4.80	12.00	VC7M
SFP	0.63	0.63	0.66	0.71	0.81	1.17	-						
AHU-HW-6	1.00	1.00	1.00	1.00	0.92	0.82	0.69	36	230v 1ph	550	6.80	17.00	VC7M
SFP	0.60	0.60	0.60	0.630	0.60	0.65	0.77						
AHU-HW-7	1.39	1.32	1.14	0.98	0.61	0.40	-	34	230v 1ph	736	7.40	18.50	VC8M
SFP	0.53	0.56	0.65	0.75	1.20	1.84	-						

Performance curves are based on "clean filter" conditions. An additional 80Pa should be added to the external pressure of the product for unit selection at a "mean dirty" condition

SFP - Specific Fan Power

### Fan Outlet Sound Levels

Model	Sound Pressure Level db A at 3m	Sound Power Levels db							
		Mid Octave Bands (Hz)							
		63	125	250	500	1000	2000	4000	8000
AHU-HW-1	40	61	70	70	59	62	54	51	47
AHU-HW-2	43	65	73	68	67	67	62	59	52
AHU-HW-3	47	76	79	73	73	73	67	65	67
AHU-HW-4	45	71	73	66	71	71	69	66	62
AHU-HW-5	50	77	79	73	74	77	77	74	69
AHU-HW-6	48	75	77	71	73	75	74	71	67
AHU-HW-7	48	78	80	72	74	74	73	72	66



### Fan, Filter and LPHW Heater Battery - Plant Models

Model-Duct	A mm	B mm	C mm	D mm	E mm	Kg
AHU-HW-1-D	950	600	450	650	500	79
AHU-HW-2-D	950	600	450	650	500	79
AHU-HW-3-D	950	600	450	650	500	79
AHU-HW-4-D	950	750	450	800	500	93
AHU-HW-5-D	950	750	450	800	500	93
AHU-HW-6-D	1050	825	500	875	550	112
AHU-HW-7-D	1350	900	600	950	650	131

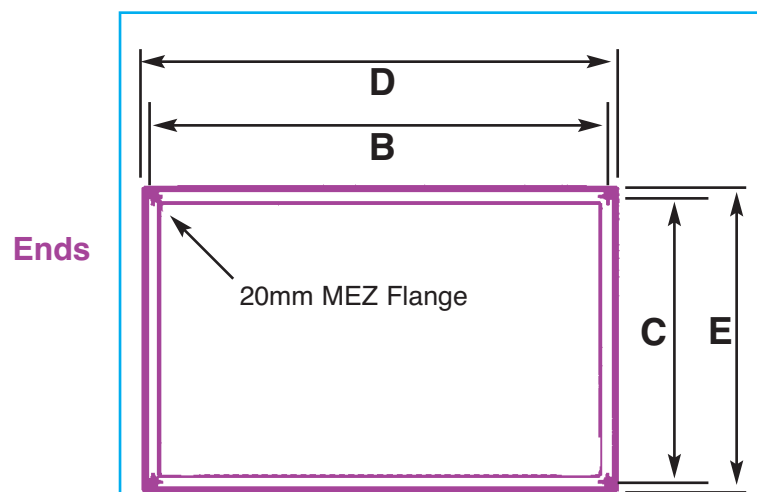
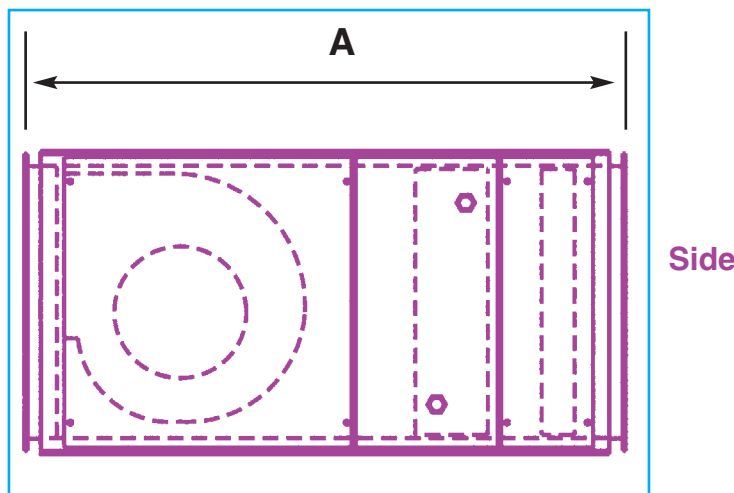



### Fan, Filter and LPHW Heater Battery - Weatherproof Models

Model-Roof	A mm	B mm	C mm	D mm	E mm	Kg
AHU-HW-1-R	1200	600	450	650	580	74
AHU-HW-2-R	1200	600	450	650	580	74
AHU-HW-3-R	1200	600	450	650 <td 580	74	
AHU-HW-4-R	1200	750	450	800	580	87
AHU-HW-5-R	1200	750	450	800	580	87
AHU-HW-6-R	1350	825	500	875	580	104
AHU-HW-7-R	1600	900	600	950	680	125

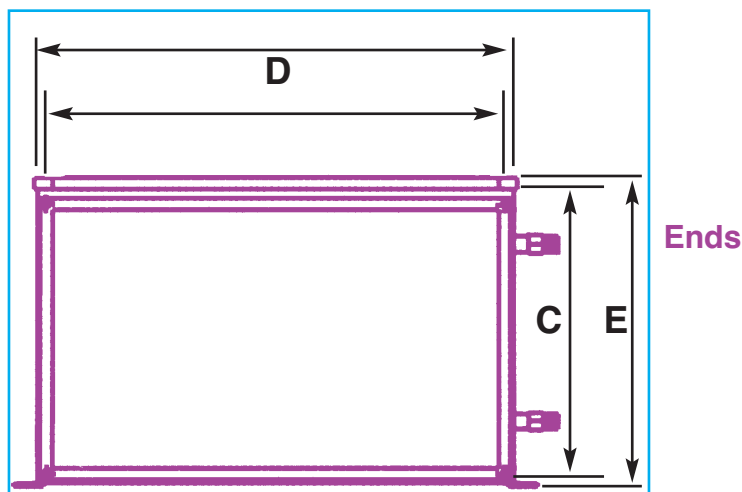
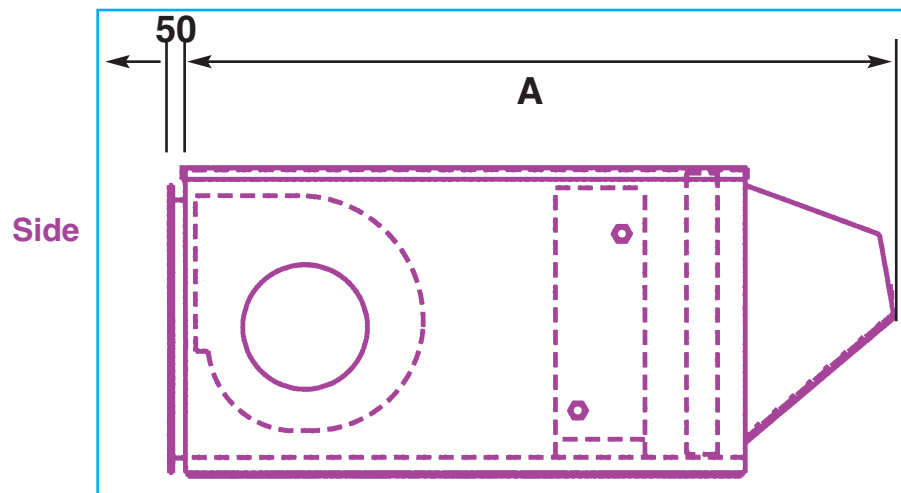

# Direct Drive - Air Handling Units Silencers



## Pressure Drop

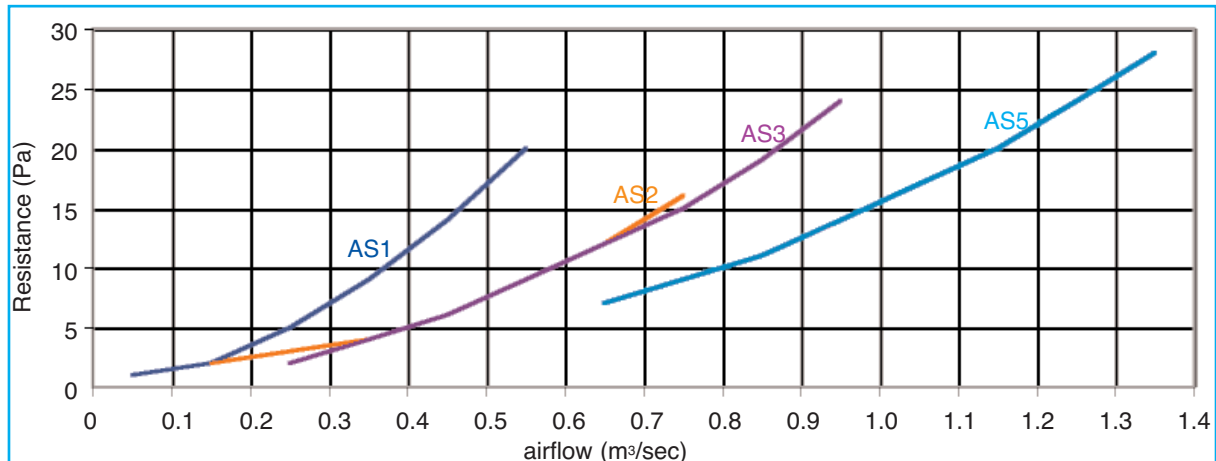

## Insertion Loss

Model	Attenuation: Insertion loss - db - mid frequency Hz							
	63	125	250	500	1000	2000	4000	8000
AS1	5	9	16	30	39	39	31	26
AS2	5	9	19	33	42	42	30	18
AS3	5	9	17	31	41	41	33	26
AS5	5	9	16	30	39	39	31	26

## Dimensions

Model	A	B	C	Kg
AS1	600	450	1000	48
AS2	750	450	1200	51
AS3	825	500	1000	80
AS5	900	600	1000	105

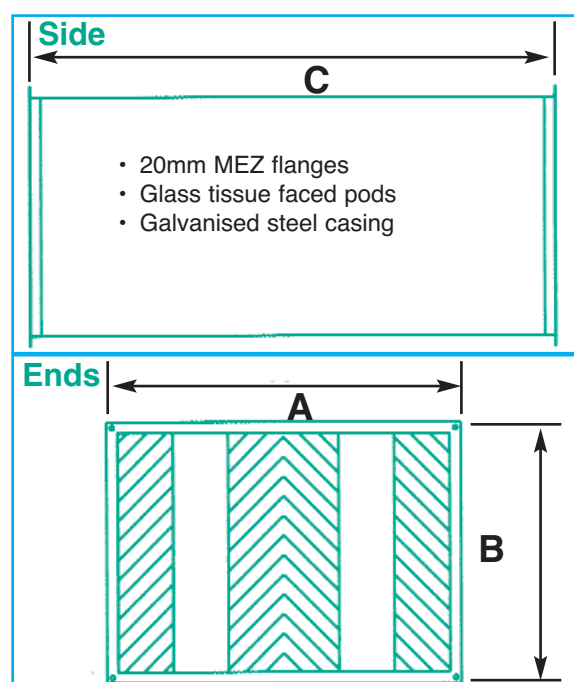

# Air Handling Units

## Control Panels



### Electric Heating

#### Single Stage Electric Heating Control Panel - ECP1

Epoxy painted steel enclosure, 160 x 250 x 125mm  
Individual switches and indicators for fan and heater  
Individual MCB for fan and heater element  
Mains input: 230v, 50Hz, 1 phase  
Maximum output: Heater 1 x 3kw 1 phase elements  
Fan 1 x 1 phase  
2A MCB fitted as standard  
Number of steps of heater control: 1



#### 3 Step Electric Heating Control Panel - ECP3

Epoxy painted steel enclosure, 300 x 400 x 150mm  
Door interlocked isolator  
Individual switches, and run and trip indicators for fan and heater  
Panel live indicator  
Individual fuses for fan and heater element  
Mains input: 400v, 50Hz, 3 phase and neutral; or 230v 50Hz 1 phase  
Maximum output: Heater 3 x 3kw 1 phase elements  
Fan 1 x 1 phase 6.3A max full load current  
2A fuse fitted as standard  
Number of steps of heater control: 3  
Fan run-on timer: approximately 2 minutes



#### 6 Step Electric Heating Control Panel - ECP6

Epoxy painted steel enclosure, 400 x 500 x 150mm  
Door interlocked isolator  
Individual switches, and run and trip indicators for fan and heater  
Panel live indicator  
Individual fuses for fan and heater element  
Mains input: 400v, 50Hz, 3 phase and neutral; or 230v 50Hz 1 phase  
Maximum output: Heater 6 x 3kw 1 phase elements  
Fan 1 x 1 phase 6.3A max full load current  
6A MCB fitted as standard  
Number of steps of heater control: 6  
Fan run-on timer: approximately 2 minutes



### Hot Water Heating

#### Hot Water Heating Control Panel - HWCP

Epoxy painted steel enclosure  
Individual switches, and run and trip indicators for fan and heater  
Panel live indicator  
Heater on indicator  
Mains input: 230v, 50Hz, 1 phase  
Maximum output: Fan 1 x 1 phase 10A max full load current



# Belt Driven - Air Handling Units

## Plant Models



## "AHU-BDP" - plant models



### Features

- for internal use only
- can be fitted with electric or LPHW heater
- 8 models (4 sizes) for duct installation
- airflow to 2.25 m<sup>3</sup>/sec
- speed controllable
- inlets and outlets fitted with "Mez" type duct connecting flanges
- rigid casing construction
- mounted on 100mm high galvanised sheet steel channel base
- side access
- bag and panel filter fitted into slide-in channels
- filter doors fitted with easy access fasteners
- quick and easy to install

### Specification

- units are manufactured from spangled galvanised sheet steel, double skinned with 25mm thick mineral wool slab insulation of 65 kg/m<sup>3</sup> density (providing high degree of acoustic insulation)
- fans are double inlet, double width, forward curved centrifugal type, mounted on integral anti-vibration mounts. Fan impellers are statically and dynamically balanced in accordance with VDI 2060 and ISO 1940/1. Supplied as standard with pre-greased sealed for life bearings having L10 life of 20,000 hours at peak performance

- standard motors of squirrel cage induction type, totally enclosed, fan cooled, suitable for 3-phase, 50Hz electricity supply.
- motors with IP55 protection and Class F rating
- fan and motor connected via vee belt drive, pre-aligned and tensioned.
- fan and motor mounted on a common chassis frame isolated from casing via open coil spring anti-vibration mounts. Flexible connector fitted between fan discharge and casing. Transit bolt fitted to prevent damage in transit
- LPHW (low pressure hot water) coils constructed from copper tubes mechanically expanded into ribbed aluminium fin plates. Coils have galvanised sheet steel casing and mounted into slide-in channels for easy removal
- electric heater batteries manufactured using sheathed incolloy 8 elements.  
The number and Kw rating to be dictated by duty, number of stages required and electrical supply. A manually resettable thermal cut-out is an integral part of heater control circuits. It is recommended that the fan run-on timer be incorporated in the controls to prevent possible heat damage.
- panel filters manufactured from bonded and coated spun glass fibre to G4 grade, fitted as standard in easily removable housings.
- **manufactured in UK to ISO9001**



### Performance

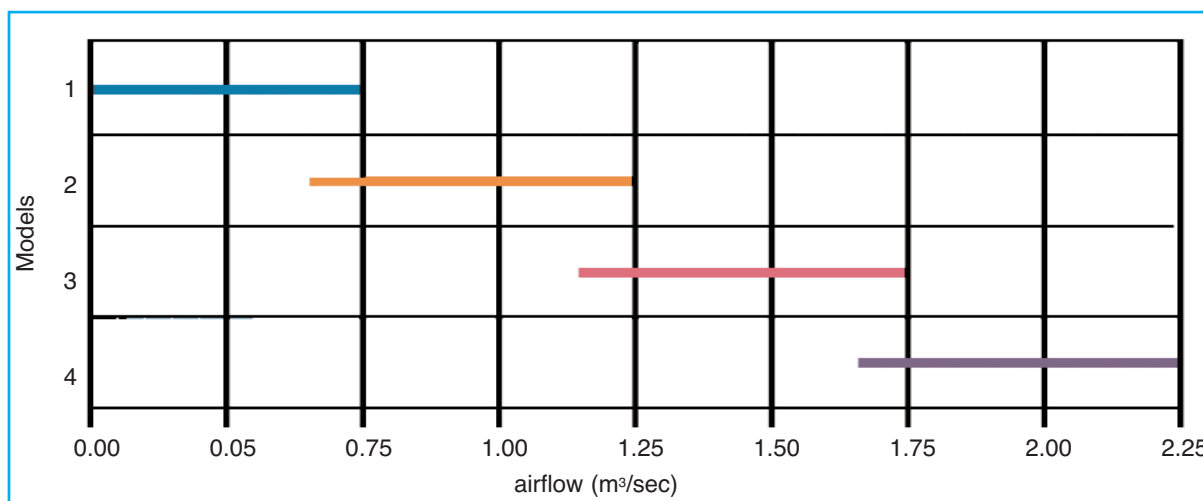

	Range	
1	AHU-BDP-E-1	AHU-BDP-HW-1
2	AHU-BDP-E-2	AHU-BDP-HW-2
3	AHU-BDP-E-3	AHU-BDP-HW-3
4	AHU-BDP-E-4	AHU-BDP-HW-4

### Fan Outlet - Sound Levels

Model	Sound Pressure Level dbA at 3m	Sound Levels: Induct dB ref 10 <sup>-12</sup> W PWL							
		Centre Frequency Levels (Hz)							
		63	125	250	500	1000	2000	4000	8000
AHU-BDP-1	66	80	79	76	74	73	71	67	63
AHU-BDP-2	67	81	80	77	75	72	72	68	64
AHU-BDP-3	69	82	81	78	76	73	73	69	65
AHU-BDP-4	71	84	83	80	78	75	75	71	67

Noise levels depend on both air volume and resistance. The above levels should be used as a guide. They have been based on the higher levels within the spectrum (although research has shown that there is not much deviation)

### Sound - Case Breakout

	Centre Frequency Levels (Hz)							
	63	125	250	500	1000	2000	4000	8000
Insertion Loss dB	9	11	13	28	34	35	35	36

# Belt Driven - Air Handling Units

## AHU-BDP - *Dimensions*



### Fan, Filter and Electric Heater Battery - Plant Models

Model	A mm	B mm	C mm	D mm	E mm	Kg
AHU-BDPE-1	1400	600	450	650	500	130
AHU-BDPE-2	1500	825	500	875	550	165
AHU-BDPE-3	1600	825	650	875	700	225
AHU-BDPE-4	1650	900	750	950	800	280

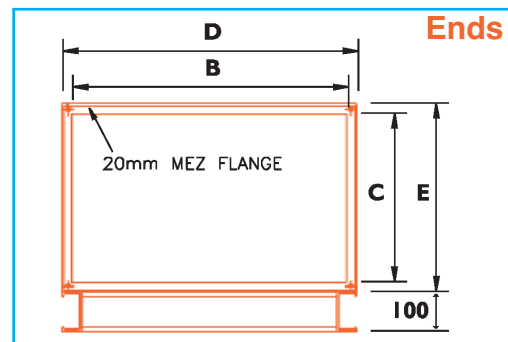
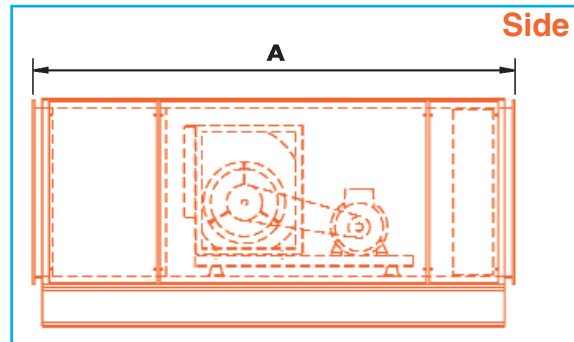

### Fan, Filter and LPHW Heater Battery - Plant Models

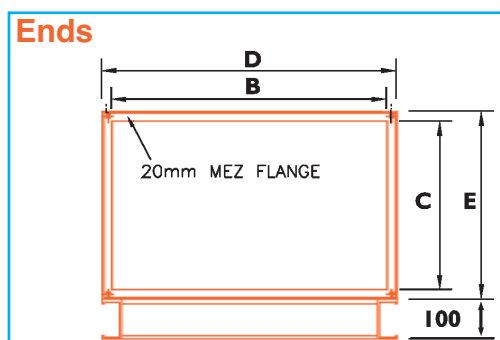
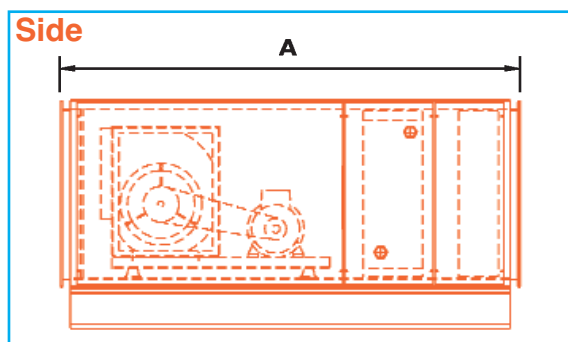

Model	A mm	B mm	C mm	D mm	E mm	Kg
AHU-BDPHW-1	1300	600	450	650	500	130
AHU-BDPHW-2	1400	825	500	875	550	165
AHU-BDHW-3	1500	825	650	875	700	225
AHU-BDHW-4	1550	900	750	950	800	280



### Electric Heater Battery

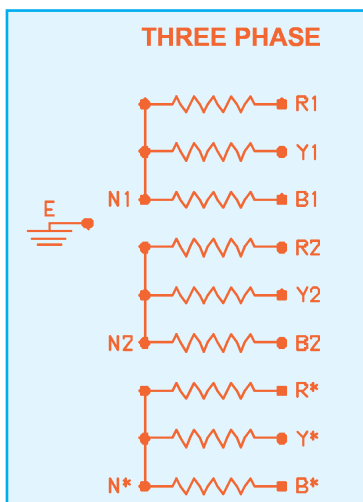
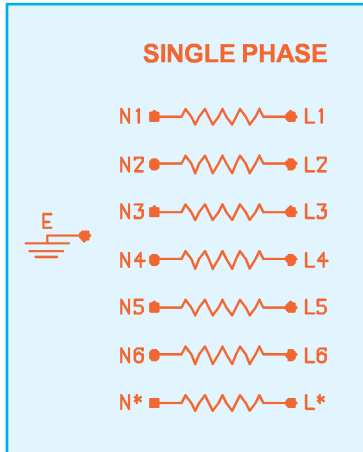

Model	kW Rating	Single Phase Steps					3 Phase Steps			
		1	2	3	4	6	1	2	3	4
AHU-BDPE-1	6.0	✓	✓	✓			✓	✓		
	9.0	✓	✓	✓			✓	✓		
	12.0	✓	✓	✓	✓	✓	✓	✓		
	15.0	✓	✓	✓		✓	✓	✓		
	18.0	✓	✓	✓		✓	✓	✓		
	24.0						✓	✓		✓
	27.00							✓	✓	
AHU-BDPE-2	9.0	✓	✓	✓			✓	✓		
	12.0	✓	✓	✓	✓	✓	✓	✓		
	15.0	✓	✓	✓		✓	✓	✓		
	18.0	✓	✓	✓		✓	✓	✓		
	24.0						✓	✓		✓
	27.0							✓	✓	
	36.0							✓	✓	✓
AHU-BDPE-3	18.0	✓	✓	✓		✓	✓	✓		
	24.0						✓	✓		✓
	27.0							✓	✓	
	36.0							✓	✓	✓
	45.0							✓	✓	
	54.0							✓	✓	✓
	63.0							✓	✓	
AHU-BDPE-4	27.0						✓	✓	✓	
	36.0							✓	✓	✓
	45.0							✓	✓	
	54.0							✓	✓	✓
	63.0							✓	✓	
	72.0								✓	✓
	81.0							✓	✓	

Heater ratings can be calculated using the following formula:  $KW = m^3/sec \times 1.21 \times Temp\ rise\ ^\circ C$   
 Dependent on external system resistance and airflow achieved, the temperature rise should not exceed 35°C

# Belt Driven - Air Handling Units Silencers



## Pressure Drop

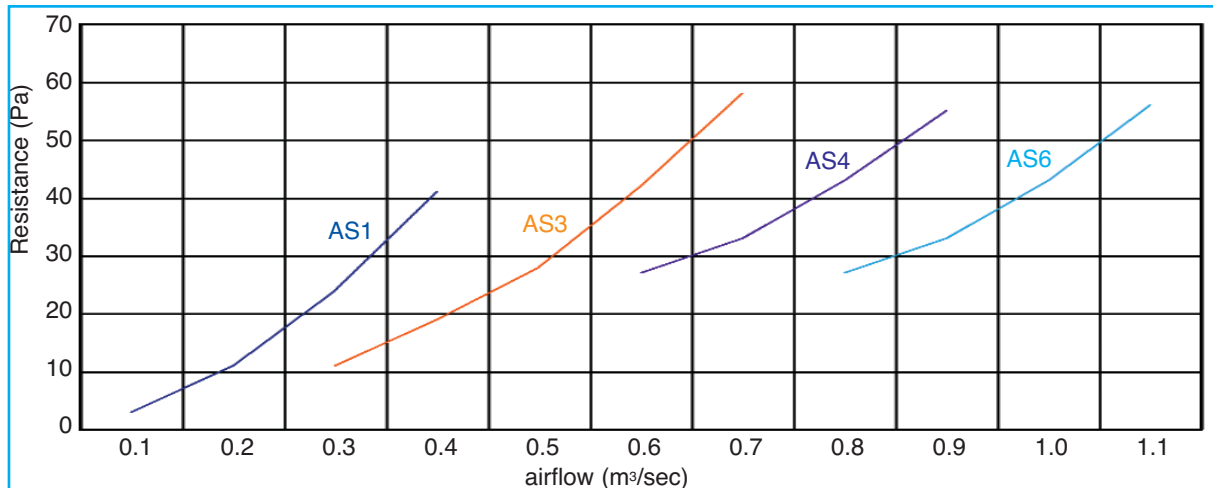

## Insertion Loss

Model	Attenuation: Insertion loss - db - mid frequency Hz							
	63	125	250	500	1000	2000	4000	8000
AS1	5	9	16	30	39	39	31	26
AS3	5	9	17	31	41	41	33	26
AS4	5	9	16	30	39	39	31	26
AS6	5	9	16	30	39	39	31	26

## Dimensions

Model	A	B	C	Kg
AS1	600	450	1000	48
AS3	825	500	1000	51
AS4	825	650	1000	80
AS6	900	750	1000	105

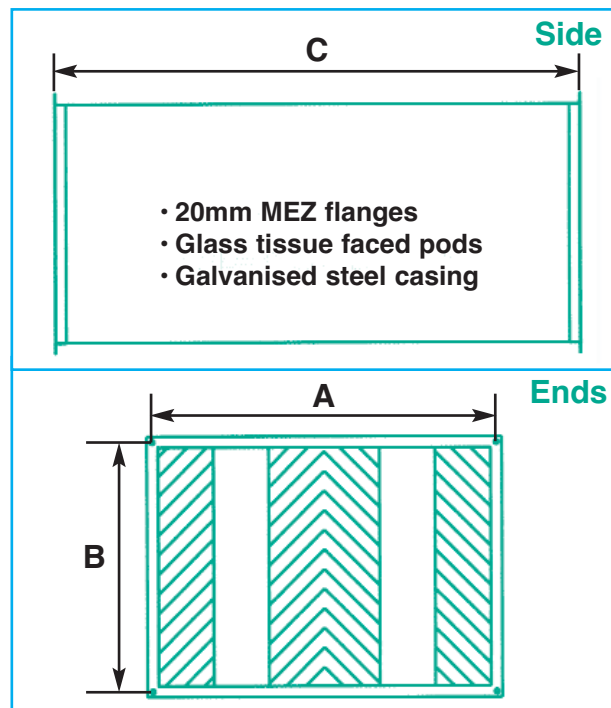

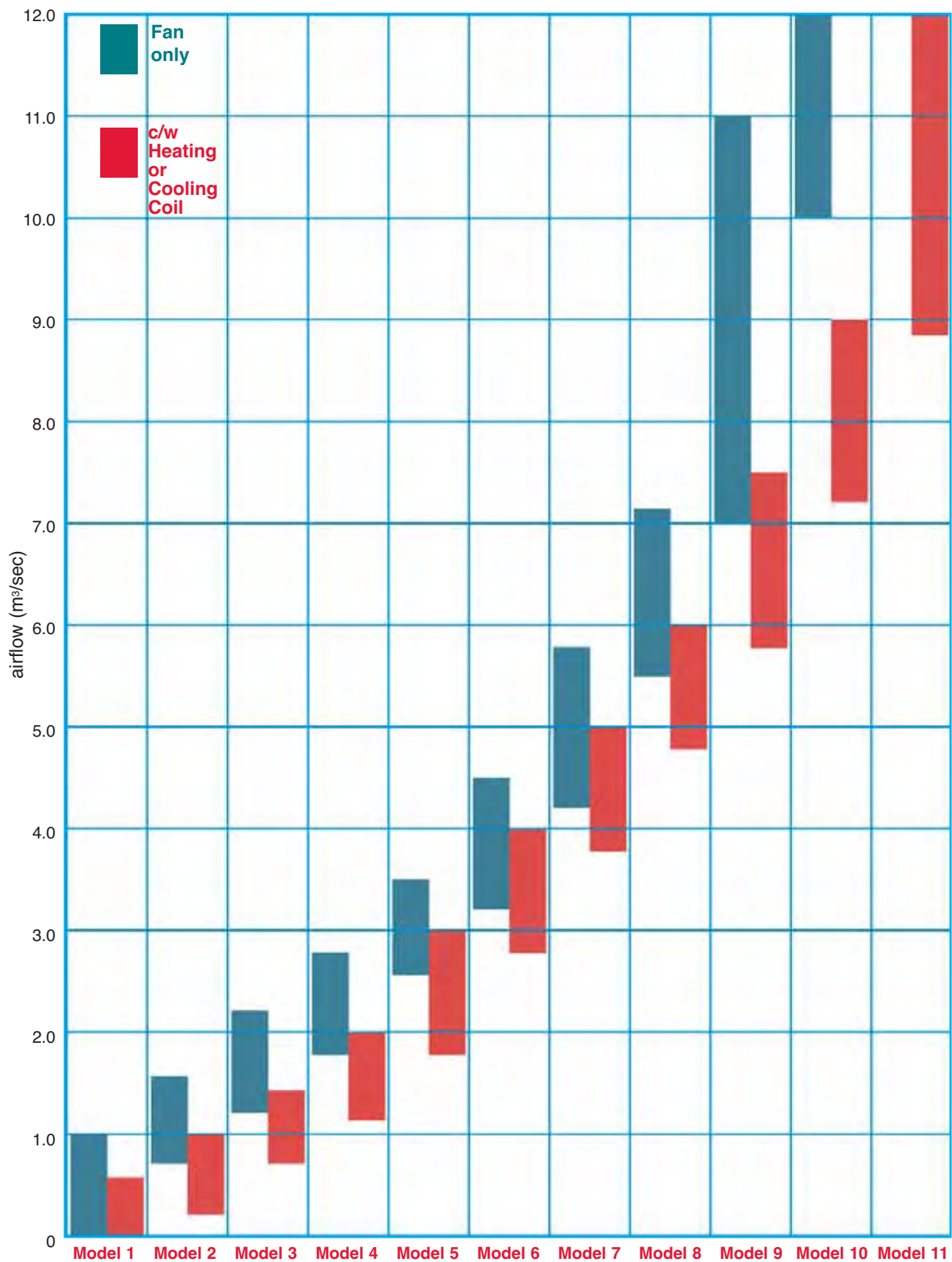

# Belt Driven Air Handling Units

## *Plant & External*



## "AHU-BDD/R"



### Features

- larger sizes for plant and external installation
- can be with electric or LPHW heater batteries
- 11 standard sizes
- airflow to 12 m<sup>3</sup>/sec
- wide selection of control panels available

### Cases - Plant Models

- robust 30 x 30 (30 x 50 on larger units) extruded aluminium frame
- black plastic corner joints
- finished in galvanised, double skinned steel with 25mm thick mineral wool slab insulation of 65 kg/m<sup>3</sup> density (providing high degree of acoustic insulation) (50mm panels with high density rockwool and barrier matt also available for lower sound levels)
- extruded aluminium channel base running full length of unit with cross members at suitable locations
- flush fitting panels
- filter and access section panels fitted with easy access fasteners - other removable panels retained via roofing bolts

### Cases - Weatherproof Models

Case construction as Plant models, except:

- outer skin with plastic coated finish (grey to BS00A05 as standard)
- weatherproof lid fitted overhanging unit by 100mm at sides and 50mm at ends
- air intake or discharge via weather cowl or louvre fitted with birdmesh

### Specification

- fans are double inlet, double width, forward curved centrifugal type, mounted on integral anti-vibration mounts. Fan impellers are statically and dynamically balanced in accordance with VDI2060 and ISO 1940/1. Supplied as standard with pre-greased sealed for life bearings having L10 life of 20,000 hours at peak performance
- standard motors of squirrel cage induction type, totally enclosed, fan cooled, suitable for 3-phase, 50Hz electricity supply.
- motors with IP55 protection and Class F rating
- fan and motor connected via vee belt drive, pre-aligned and tensioned.
- fan and motor are mounted on a common chassis frame isolated from casing via open coil spring



anti-vibration mounts and flexible connector fitted to fan discharge. Transit bolt fitted to prevent damage during transport

- LPHW batteries are constructed from copper tubes mechanically bonded onto aluminium fins supplied with standard BSP male connectors. Option of vinyl coating (copper and electro-tinned copper also available). The coil casing is in galvanised sheet steel.
- moisture eliminator plates manufactured from polypropylene fitted where necessary. Coils are mounted on slide-in channels to aid removal.
- electric heater batteries for single and 3 phase operation are manufactured from sheathed rod elements with an integral manually resettable thermal cut-out for wiring into control unit. It is recommended that fan run-on timer is incorporated in controls to prevent possible heat damage.
- panel filters to G4 grade mounted in side channels. Bag filters of F5 and above are mounted in purpose made front withdrawal holding frames and

retained by spring loaded clips.

- mixing box/intake dampers of opposed blade, multi-leaf type fitted aerofoil section blades. Extended shaft for fitting of suitable motor is provided as standard.
- the cross flow type heat exchangers are made from aluminium plate and mounted in galvanised sheet steel casing. Summer operation bypass damper fitted where required. Stainless steel drain pan provided on the exhaust side.
- attenuators manufactured with galvanised sheet steel case fitted with "Mez" type flange at each end.  
Splitter design shall be of such as to reach required noise criteria. Splitters formed using 65kg/m<sup>3</sup> density rockwool slab with glass tissue facing airway.  
Attenuators designed to bolt directly to end of unit shall have splitters set back to allow even air distribution.
- **manufactured in UK to ISO9001**



# Belt Driven Air Handling Units

## AHU-BDD/R - *Features and Dimen*

### Size - mm

Model	1	2	3	4	5	6	7	8	9	10	11
<b>A mm</b>	800	800	1075	1350	1350	1400	1675	1950	1950	1950	2550
<b>B mm</b>	500	800	800	800	1100	1450	1450	1450	1750	2100	2100
<b>C mm</b>	400	500	500	500	500	600	600	-	-	-	-
<b>D mm</b>	810	910	1010	1060	1185	1260	1360	1500	1750	1750	2000
<b>E mm</b>	400	500	500	500	500	600	600	700	700	700	700
<b>F mm</b>	250	250	250	250	250	250	280	200	300	300	350
<b>G mm</b>	900	1000	1000	1000	1150	available upon application					
<b>H mm</b>	500	500	500	500	500	500	500	500	500	500	500
<b>I mm</b>	200	200	200	200	200	200	250	250	250	250	300

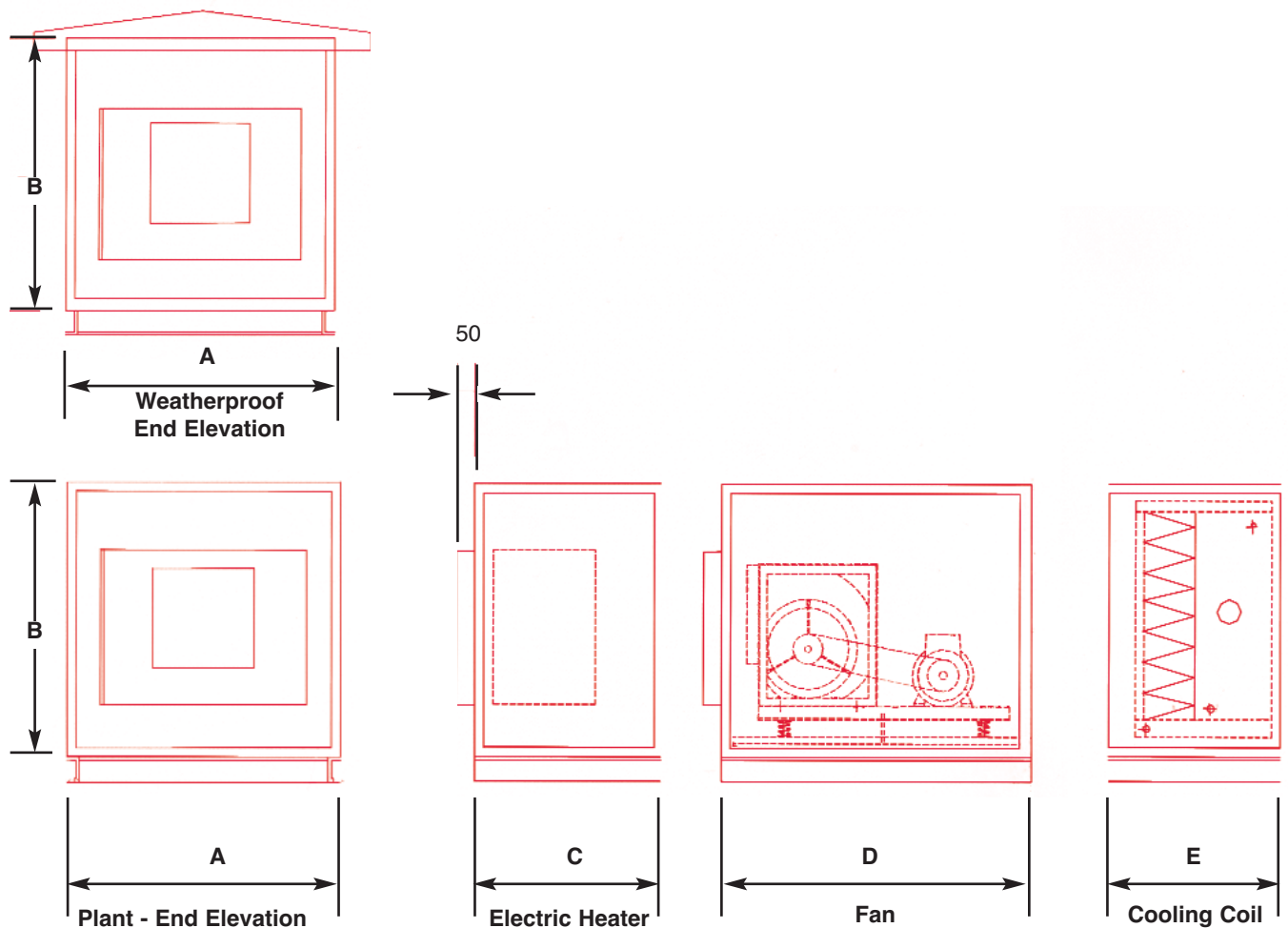

## Weight - kg

Model	1	2	3	4	5	6	7	8	9	10	11
Electric Heater	61	74	85	110	130	173	208	247	298	361	476
Fan Section	101	111	127	139	160	193	329	261	317	356	427
Cooling Coil	88	109	121	151	179	220	265	308	361	420	508
Heating Coil	41	50	60	70	79	88	103	122	147	263	320
Heat Exchanger	137	151	167	194	235	available upon application					
Bag Filter	52	63	71	87	110	140	165	188	221	260	328
Panel Filter	21	25	30	35	39	43	48	52	57	63	70

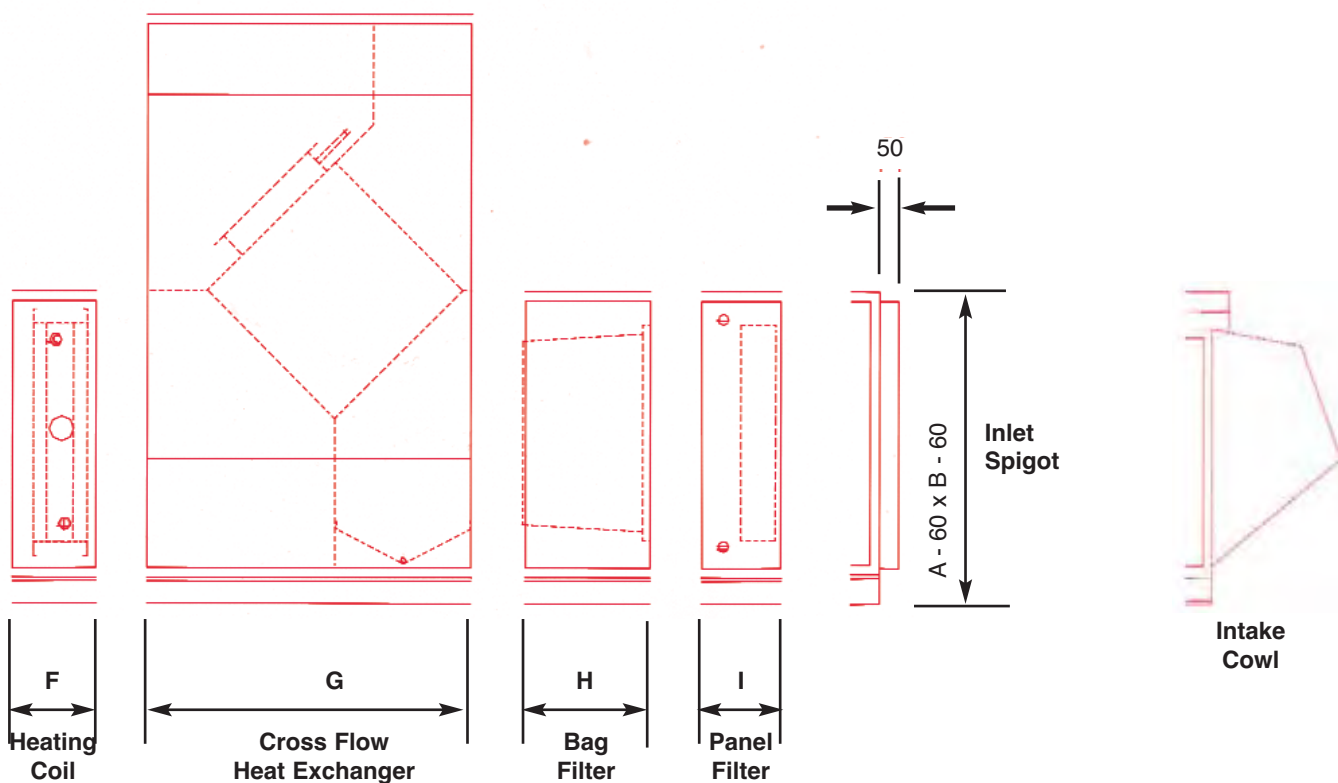

# Air Handling Units

## Custom Built



### General

Vectaire offers an extensive range of supply/extract units and associated ancillary equipment. Fans are available which cater for air volumes up to 20 m<sup>3</sup>/sec, for both internal and external applications. Most design parameters can be accommodated, and among the many variants we are able to provide are the following.

### Cases

- single or double skinned with 25mm or 50mm thick panels.
- different panel infill, including a combination of high-density rockwool and barrier mat to give high noise reduction.
- differing panel skin materials including stainless steel, aluminium and plastic coated sheet steel.
- powder coat paint finish to any BS or RAL number to either internal, external or both surfaces.
- casings supplied in "flat pack" form to facilitate site assembly.

### Components

- The following components can be readily catered for:
  - **filters**
    - carbon
    - hepa
    - grease
    - washable
  - run-a-round coil systems
  - thermal wheels
  - gas fired heaters - indirect and direct
  - **fans**
    - SISW
    - duplex (for low profile)
    - twin motors
    - single phase
    - 2 speed
    - mounted out of air stream
    - fitted with standby

### Specifications

- units can be designed to meet the requirements of the following:
  - DEO Spec 037
  - CO4

### Controls

- any variation of control package can be supplied:
  - simple pre-wiring of motor to an external isolator
  - an in-built control panel pre-wired to motors, damper motors, sensors etc

# Air Handling Units

## *Custom Built*



# direct drive - belt drive - custom built *Air Handling Units*



## Contracts Completed

Aston Martin  
BUPA Hospital, Leicester  
Neville Hall Hospital  
RAF Odiham  
RAF Benson  
RNAS Clyde  
Lyreco  
HP Foods  
Calypso Soft Drinks  
Disney Stores  
Princess of Wales Hospital  
Royal Yacht Britannia

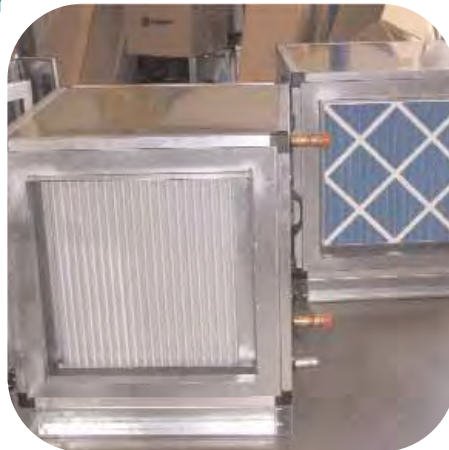

Burger King  
Warner Holiday Camp  
Bass Inns  
Livingstone FC  
Hambden Park  
Blackburn Rovers FC  
Waitrose  
Kentucky Fried Chicken  
Domino Pizza  
Sandwell Hospital  
Featherstone Technical College





**Bag  
Filters**

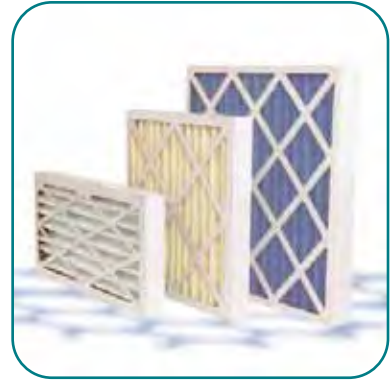

**Panel  
Filters**



**Pressure  
Switch**



**Elements**



**Speed  
Controllers  
for BAHU and  
AHU-E**



**Manometer**

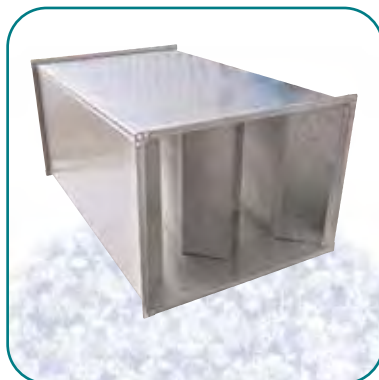

**Silencer**



**Anti  
Vibration  
Mounts**

## Other Vectaire Ventilation Units



**"Microbox"**  
for Apartment Ventilation



**WHHR150 & 250**  
Whole House  
Heat Recovery



**"ACFS"**  
**SUPER SILENT**  
Acoustic Cabinet Fans



**"DMTSQ"**  
Twin, Slimline  
Acoustic Fans

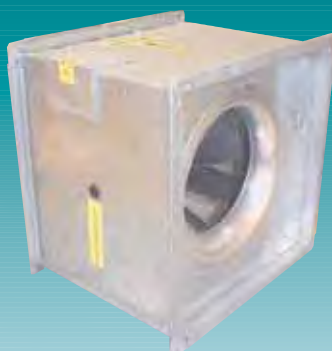

**"SMX"**  
Square Cased Mixed  
Flow Fans



**"Heatrec"**  
Heat Recovery  
Units

**Vectaire Ltd**  
Lincoln Road  
Cressex Business Park  
High Wycombe  
Buckinghamshire, HP12 3RH  
Tel: +44(0)1494 522333  
Fax: +44(0)1494 522337  
Email: [sales@vectaire.co.uk](mailto:sales@vectaire.co.uk)  
Web: [www.vectaire.co.uk](http://www.vectaire.co.uk)

